

## DATA SHEET

# Si-83

## Tank Pump

Sauerermann® part #: SI83CE04UN23 - SI83CE74UN23



### The Tank Pump Re-Invented

Sauerermann engineers have redesigned the tank pump from the inside-out, making the Si-83 more durable, compact, and powerful than any other tank pump in its class, all while redefining just how easy tank pump installation and maintenance can be in the field. The Si-83 even comes with a customized Smartphone App that makes installation both simple and intuitive.

The Si-83 is constructed from rugged materials and components for exceptional durability and reliability. And its unmatched versatility means that the Si-83 tank pump from Sauerermann primarily dedicated to air conditioning and refrigeration applications is equally proficient for heating applications.

### Benefits



#### Very High Performances

- 700 l/h max flow rate
- Max. pressure: 5.7 m
- 2-Liter tank capacity



#### Quicker & Easier Maintenance

- No need remove pump from installation to clean
- Removable anti-return valve
- Replacement to Si-1801, Si-1805 & Si-82
- Maintenance function in the Smartphone App (available for both iOS and Android devices)



#### Quicker & Easier Installation in any place

- Designed for intuitive installation
- Can be floor-mounted, wall-mounted, or suspended from the ceiling
- 6 inlet options for unmatched versatility Ø 30 mm: 4 on top, 1 on either side for low condensate entry
- Rod mounting system makes levelling easy
- Can be easily installed whatever the lay out of the premises thanks to its very compact profile: 129 mm in height
- Customized Smartphone App (available for both iOS and Android devices)



#### Exceptional Durability and Reliability

- Float design resistant to fouling
- Stainless steel motor shaft
- Tolerates both high-temperature and acidic condensates (pH >2.5) produced by gas-condensing boilers

### Kit content

- One-piece centrifugal pump with 2 l tank
- Integrated barb end check valve, Ø ext. 10 mm
- 1.8 m power cord, plug
- Built-in safety switch, 1 m wires, stripped wires: NC (SI83CE04UN23), NC/NO (SI83CE74UN23)
- 2 screws, 2 plugs
- Straight connector with tube and zip tie for Ø 6 mm int. tubes



## Technical specifications

<b>Max flow rate (l/h)</b>	<b>700 l/h</b>
Tank capacity	2 l
Mains supply	230 V~ 50 Hz - 115 W – 1.4 A
Max discharge head	5.4 m (65 l/h)
Max pressure (flow rate 0)	5.7 m
Max condensate temperature	55°C, 80°C short peaks 10 minutes
Max condensate acidity	pH > 2.5 (Gas condensing boilers)
Pump Weight (with packaging)	1.83 kg
Box dimensions	L 315 mm x W 151 mm x H 175 mm
Masterpack	L 780 mm x W 332 mm x H 203 mm
Pallet quantity	105 pieces (EUR size)
Safety switch	SI83CE04UN23: NC: 5 A resistive 250 V SI83CE74UN23: NC/NO: 5 A resistive 250 V
Thermal protection (overheating)	Yes: 120°C (auto reset)
Operating conditions	7% non continuous
Class	I
IP index	IP44
Safety standard	CE
RoHS directive	Compliant
WEEE directive	Compliant

## Applications

- Column air conditioning units
- Multi cassettes
- Ducted units
- High-efficiency gas furnaces
- Refrigerating display cabinets
- Evaporators
- Gas-condensing boilers

## Accessories

Name	#Part
 Clear PVC tubing Ø int. 10 mm, 25 m roll	ACC00911 ACC00915 (braided)
 Non-Return Check valve for Ø ext. 10 mm tubes	ACC00925
 3 size multi adaptor to be used for Ø 15/17 - 20 - 24/25 - 32 - 40 mm tubes	ACC00939

## Dimensions

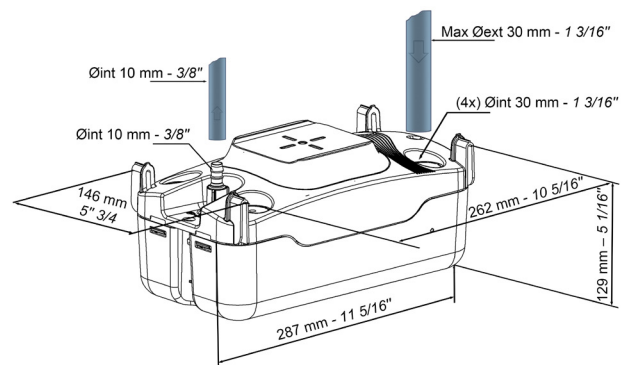

## Actual flow rates (l/h)

Discharge head	Total tube length using Ø int. 10 mm			
	5 m	10 m	20 m	30 m
1 m	372	324	243	186
2 m	314	275	203	180
3 m	270	227	162	120
4 m	190	144	96	84
5 m	112	22	8	-

